

Een vooruitblik op innovatie
vanuit EU projecten:
HeritACE & SEEDS



Glenn Reynders (KU Leuven – EnergyVille)
Warmtepomp symposium 2024

Energy system integration at the center of innovation

The energy system today :
linear and wasteful flows of energy,
in one direction only

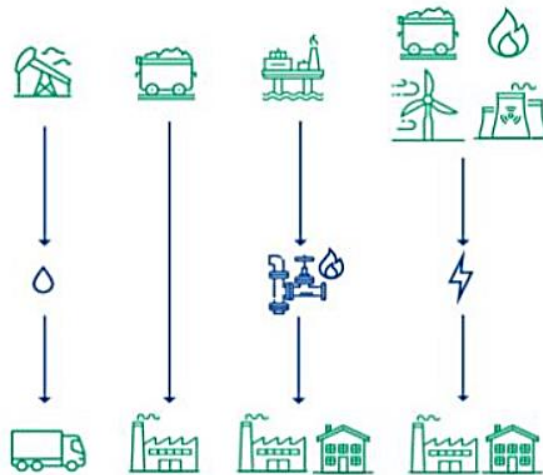

Future EU integrated energy system :
energy flows between users and producers,
reducing wasted resources and money



©European Union

*“Energy system integration will make it **easier to optimise and modernise** the EU’s energy system as a whole...
..., across **multiple energy carriers** (electricity, heat, cold, gas, solid and liquid fuels), infrastructures and consumption sectors, by
creating stronger links between them with the objective of **delivering decarbonised, reliable and resource-efficient energy
services, at the least possible cost for society.**” – DG ENER, EC*

2 EU projects in the picture

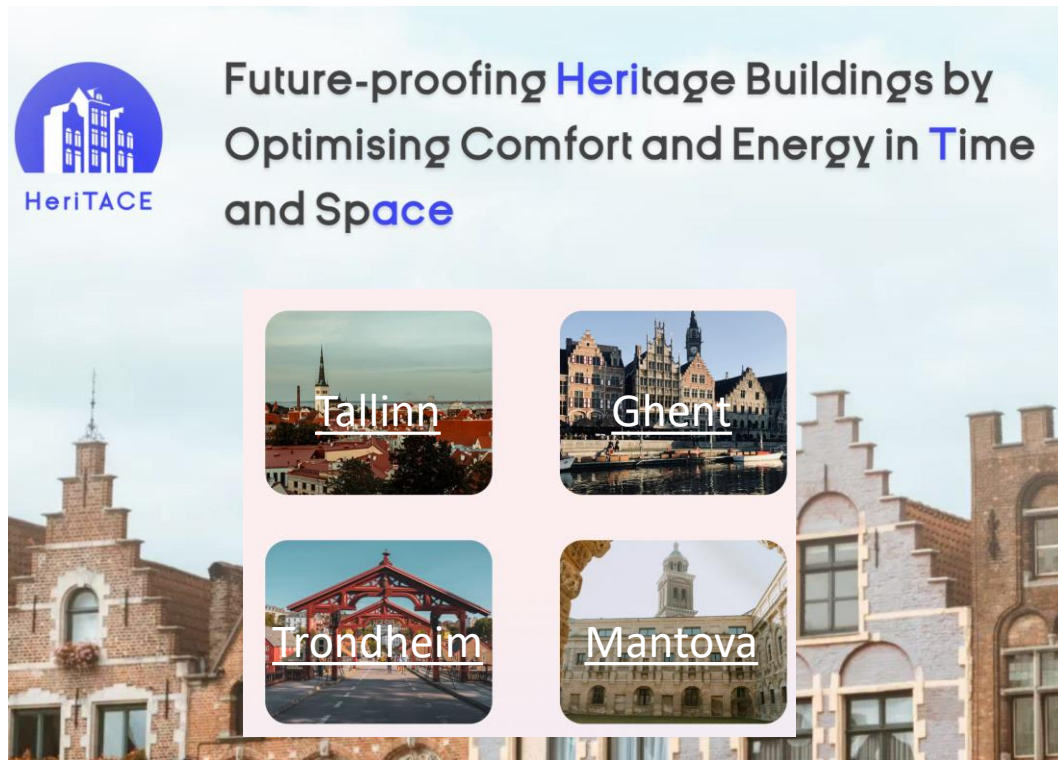

HeriTACE logo: A blue circle containing a white silhouette of a building with a clock tower, with the text "HeriTACE" below it.

Future-proofing **Heritage** Buildings by Optimising Comfort and Energy in **Time** and **Space**

Four inset images showing heritage buildings in different cities:

- Fallinn
- Ghent
- Trondheim
- Mantova

www.heritace.eu

Grant Agreement n°101138211

Horizon Europe Research & Innovation action (HORIZON-CL5-2023-D4-01)

2024-2027 (4 year)



SEEDS logo: A green leaf with a white snowflake inside a circle, next to the text "SEEDS".

SEEDS project

SEEDS project: Cost-effective and replicable Renewable Energy Sources integrated electrified heating and cooling systems for improved energy efficiency and demand response.

The SEEDS project is co-funded by the European Commission and aims to boost the electrification of thermal systems in buildings through an integrated approach leveraging energy efficient renovation and smartification of HVAC systems.

LEARN MORE

- THE PROJECT
- THE CONSORTIUM
- THE DEMO SITES
- HORIZON EUROPE

www.project-seeds.eu

Grant Agreement n°101138672

Horizon Europe Innovation action (HORIZON-CL5-2023-D4-01-05)

2024-2027 (4 year)



HERITACE

Future-proofing Heritage Townhouses by Optimising Comfort and Energy in Time and Space

HERITACE



HeriTACE project data

- Horizon Europe ‘Research and Innovation Action’
 - Call: Future-proofing historical buildings for the clean energy transition
 - Two projects granted (out of ~20): HeriTACE & FuturHist
- Granting authority: European Climate, Infrastructure and Environment Executive Agency (CINEA)
 - Ms Rebecca Kanellea (project officer)
 - Budget: ~4,5 MLN EUR
 - Project number: 101138672
- Start 01/01/2024 – 31/12/2027 (4 years)
- Coordinator: Ghent University Building Physics research group
- Beneficiaries: 17 partners from 6 EU countries

HERITACE



HeriTACE consortium

- **Researchers: buildings, HVAC, energy systems**
 - Universiteit Gent (UGent)
 - Tallinn University of Technology (TALTECH)
 - Katholieke Universiteit Leuven (KU Leuven)
 - Norwegian Building research institute (SINTEF)
 - European Academy of Bolzano (EURAC)
- **Researchers: heritage architecture and conservation**
 - Politecnico di Milano (POLIMI)
 - Norwegian Institute for cultural heritage research (NIKU)
- **Conservation (and climate) authorities**
 - City of Ghent
 - Estonian ministry of Cultural heritage
- **SME's and Industry**
 - Energy systems: ZH Spinoff (Italy)
 - System controls: Builtwins (Belgium)
 - Engineering and consulting: SWECO Belgium & Finland
 - Building materials: Sakret (Estonia)
 - Building contractor/carpenter: Denys (Belgium)
- **Communication and exploitation experts**
 - Architects Council Europe (ACE/CAE)
 - LGI Sustainable innovation



Objectives



Develop a holistic model and standard processes for renovating heritage townhouses in historical areas.



Implement integrated design approaches for deep heritage townhouse renovation, prioritizing minimal disruption.



Identify durable insulation and air tightness solutions that respect heritage values.



Design smart HVAC concepts for heritage townhouses, optimizing comfort and air quality.



Integrate local renewable energy solutions into heritage buildings for sustainable energy use.

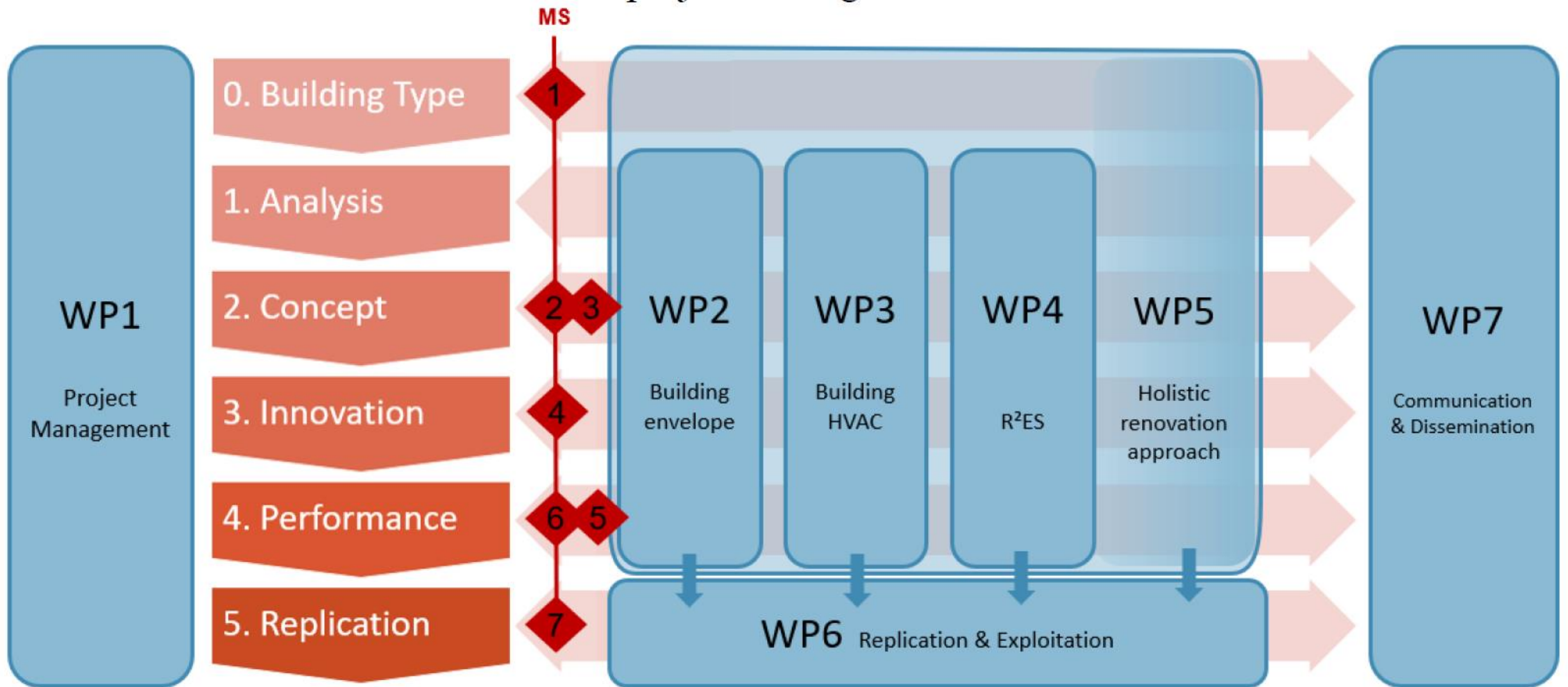

Holistic and multi-scale approach for an inclusive energy transition

INPUT FROM
WP2 (BUILDING ENVELOPE)
WP3 (BUILDING HVAC)

INPUT TO
WP5 (HOLISTIC RENOVATION
APPROACH)
WP6 (REPLICATION &
EXPLOITATION)
WP7 (COMMUNICATION &
DISSEMINATION)

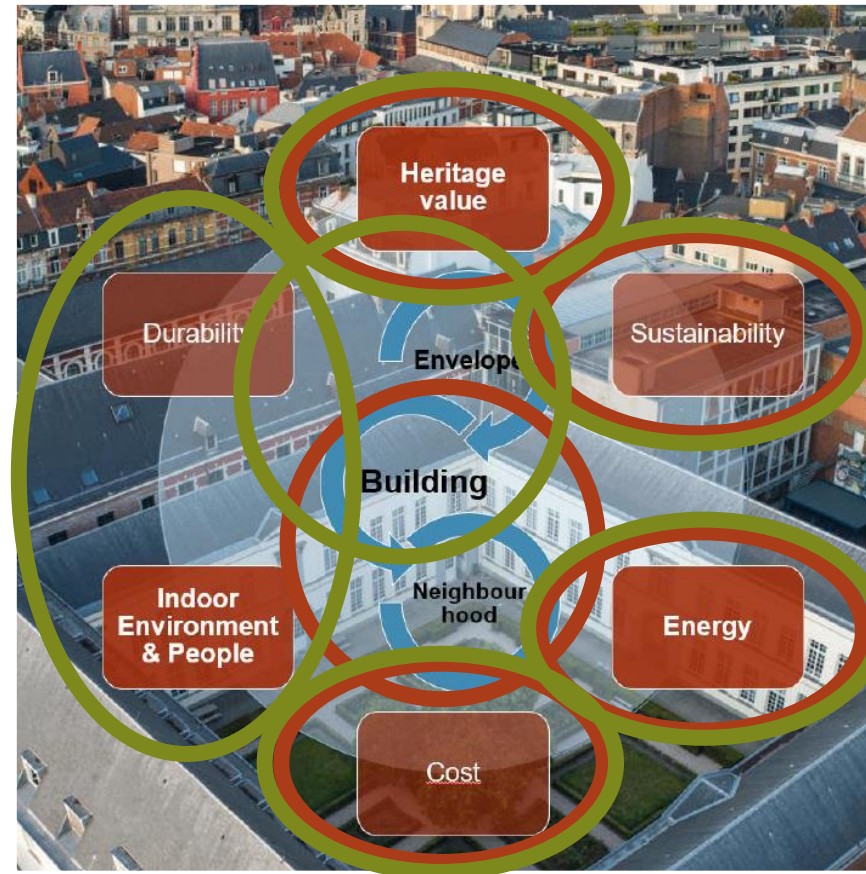

WP4
CLEAN ENERGY SUPPLY
CONCEPTS FOR HISTORICAL
BUILDINGS AND
NEIGHBOURHOODS

Setting the scene

CONTEXT

- Constraints – heritage
- Opportunities – local resources

LOCAL ENERGY SOURCES

- Renewable
 - Residual
- } R²ES

INNOVATIVE CLEAN ENERGY SUPPLY

- Cost-effective Building Integrated PV roof tiles (BIPV)
- Heat **recovery** concepts from unharvested local sources (solar-heated attics, underground parking spaces)

INTEGRATED SOLUTIONS

- Clean energy **supply and exchange** concepts (3 climate zones)
- Calibrated Model Predictive Control (MPC) as system integrator
- Integrated optimal control and sizing (IOCS)

PERFORMANCE

- Simulation-based assessment
- Automated Fault Detection by Continuous Commissioning



RENOVATION

- Individual building
 - Current best practice
 - IOCS
- Neighbourhood

**Recommendations for
context-based
individual building design
as part of a broader system**

Clean energy supply concept design

Through interdisciplinary examination of the common and specific

characteristics of both individual heritage building

- Workshops to define & discover different contexts
- Focus on 'clean' solutions design'
- LONGLIST → SHORTLIST

Buildings
Infrastructure
Hydrologist
Cityplanner
Energy

Building Physics
Influence of water & sewage systems
Historical city growth
Materialization of the built environment
Specific heating & cooling demands

and those of neighbourhoods in historical city centre, discovering & defining the potential of the built environment in 3 different climate zones

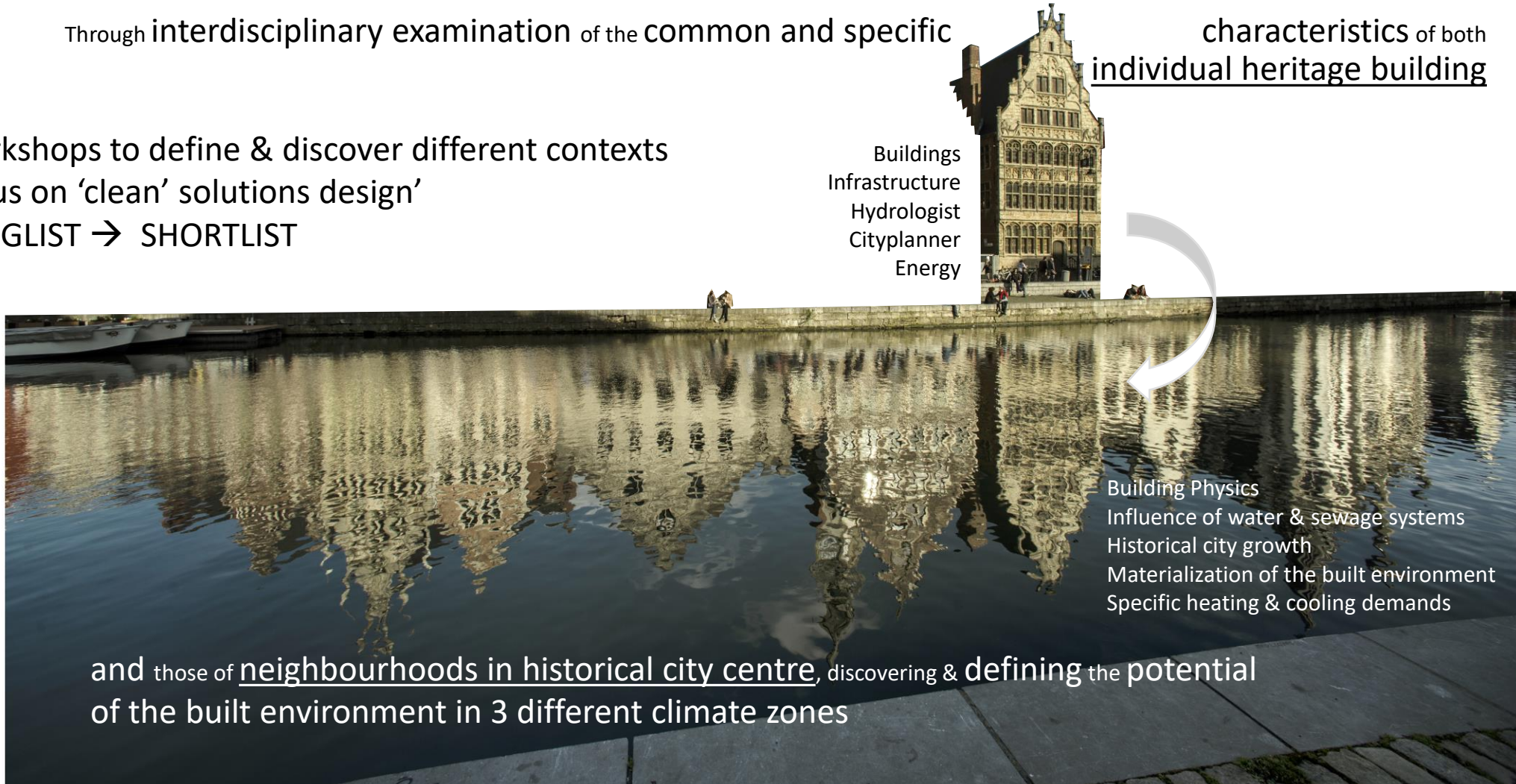

2 EU projects in the picture

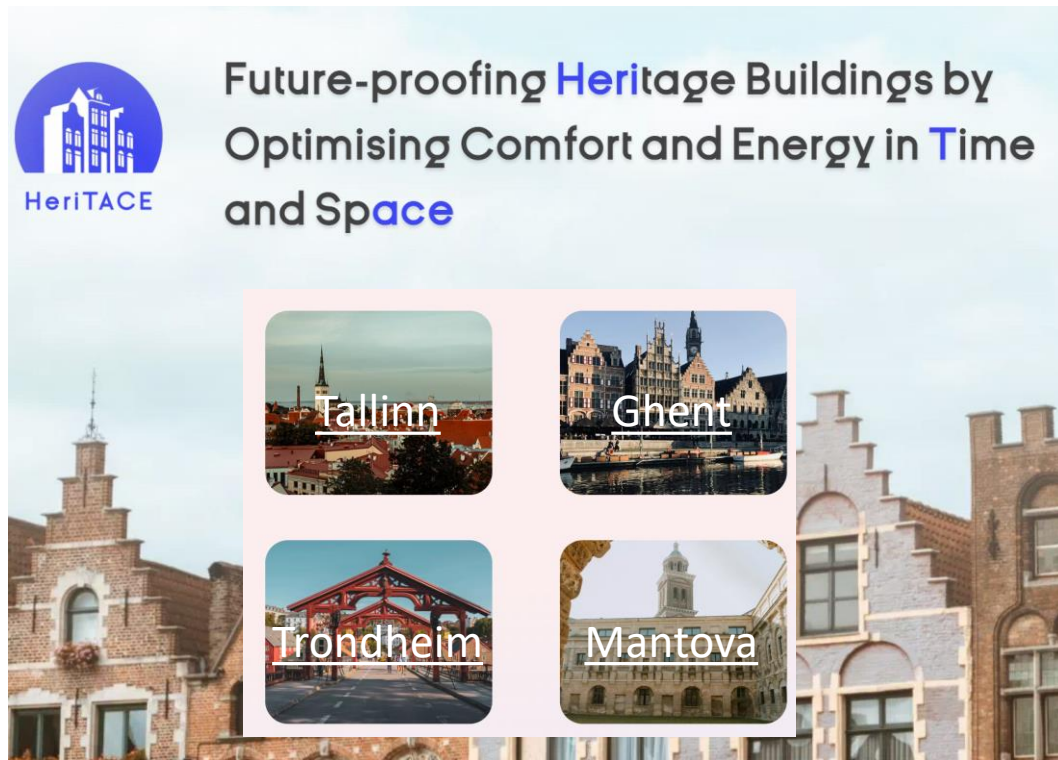

HeriTACE logo: A blue circle containing a white silhouette of a building with a clock tower, with the text 'HeriTACE' below it.

Future-proofing **Heritage** Buildings by Optimising Comfort and Energy in **Time** and **Space**

Four images in a 2x2 grid showing heritage buildings in Tallinn, Ghent, Trondheim, and Mantova.

www.heritace.eu

Grant Agreement n°101138211

Horizon Europe Research & Innovation action (HORIZON-CL5-2023-D4-01)

2024-2027 (4 year)



SEEDS logo: A green leaf with a white snowflake inside a circle, next to the text 'SEEDS'.

Navigation menu: ABOUT, NEWS & EVENTS, RESOURCES, CONTACT US, NEWSLETTER, in, twitter.

SEEDS project

SEEDS project: Cost-effective and replicable Renewable Energy Sources integrated electrified heating and cooling systems for improved energy efficiency and demand response.

The SEEDS project is co-funded by the European Commission and aims to boost the electrification of thermal systems in buildings through an integrated approach leveraging energy efficient renovation and smartification of HVAC systems.

LEARN MORE

THE PROJECT, THE CONSORTIUM, THE DEMO SITES, HORIZON EUROPE

www.project-seeds.eu

Grant Agreement n°101138672

Horizon Europe Innovation action (HORIZON-CL5-2023-D4-01-05)

2024-2027 (4 year)



EU-HORIZON-CL5-2023-D4-01-05 call SEEDS

Cost-effective and replicable
RES-integrated
electrified heating and cooling systems
for improved energy efficiency and demand response



SEEDS concept, consortium en pilots



26 partners uit 8 landen, 6 pilots in BE, DK, SI, HU, EL

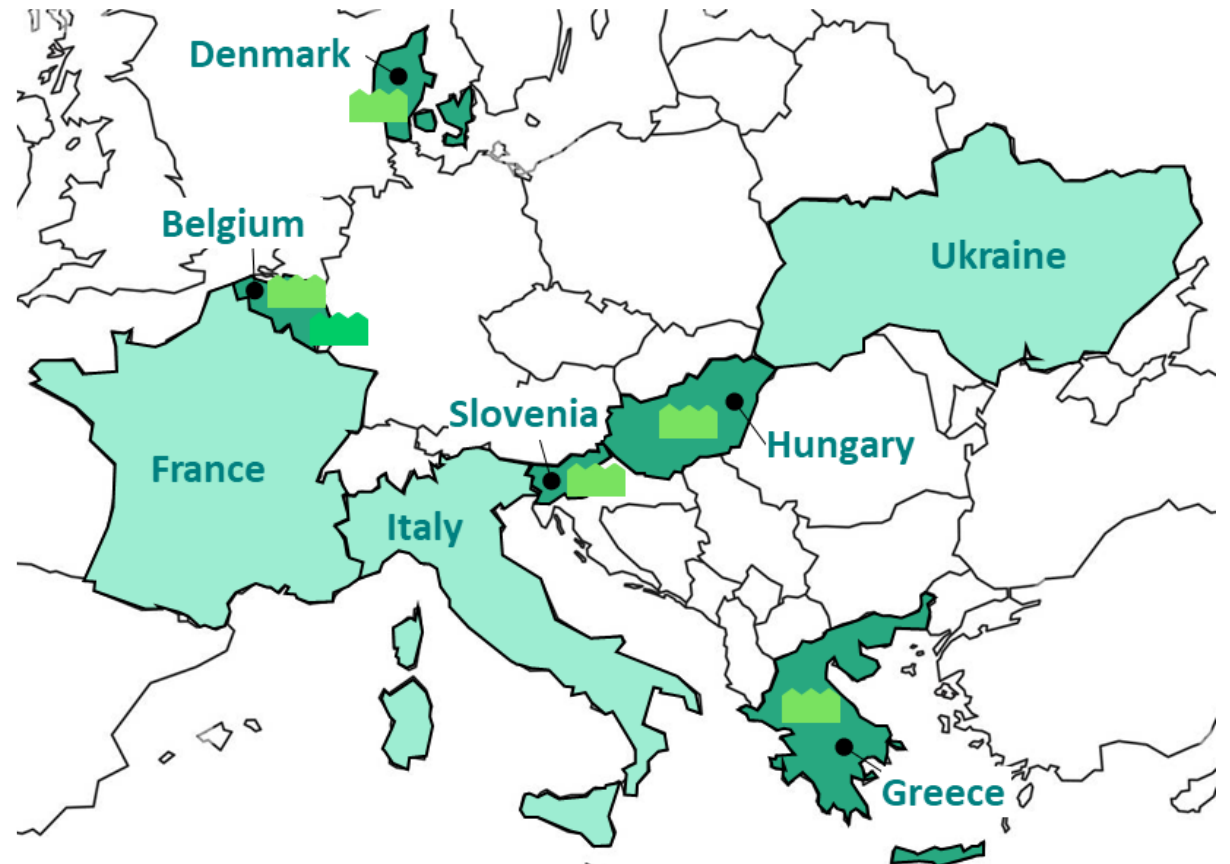
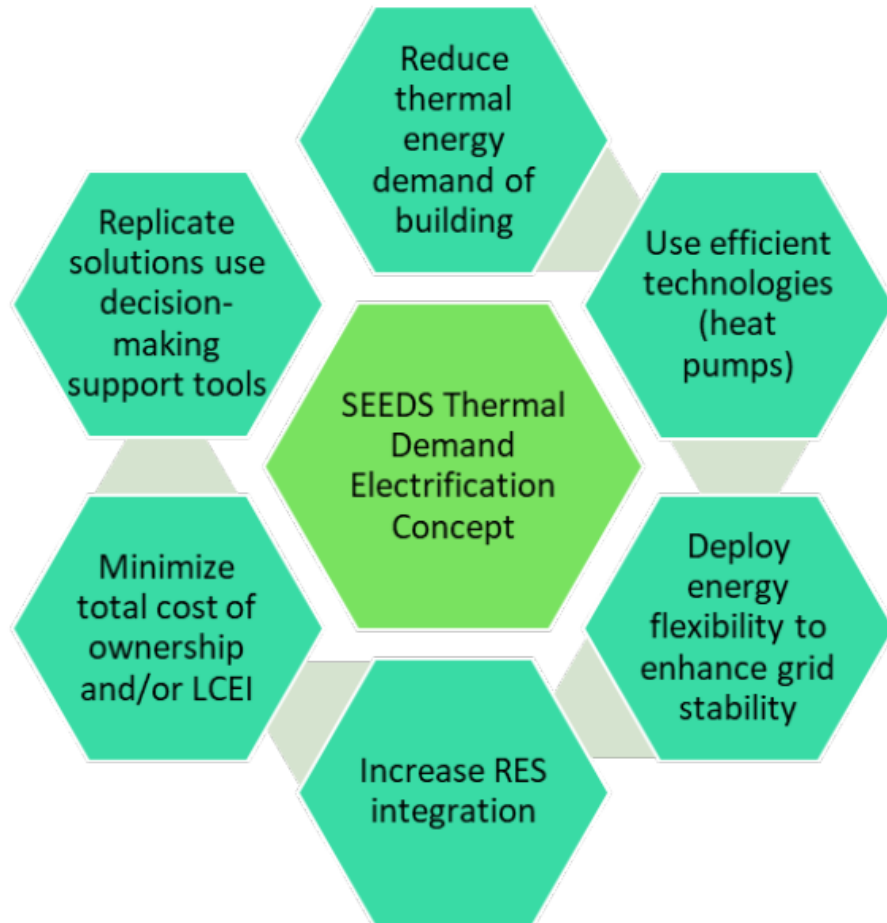

BELGISCHE PILOTS

Clean (R²ES) Hybrid (systeemprestatie) Collective (OPEX & CAPEX) Concept

Living Lab

Extra vrijheidsgraden laten toe
innovatieve inzichten te verwerven

vertaling

Replicatie

Eenvoudigere afgeleide, illustratie van
haalbare aanpak in de praktijk



INITIATIEFNEMERS

De Schipjes 1.0 en De Schipjes 2.0

Prof. Lieve Helsen & Prof. Wim Boydens

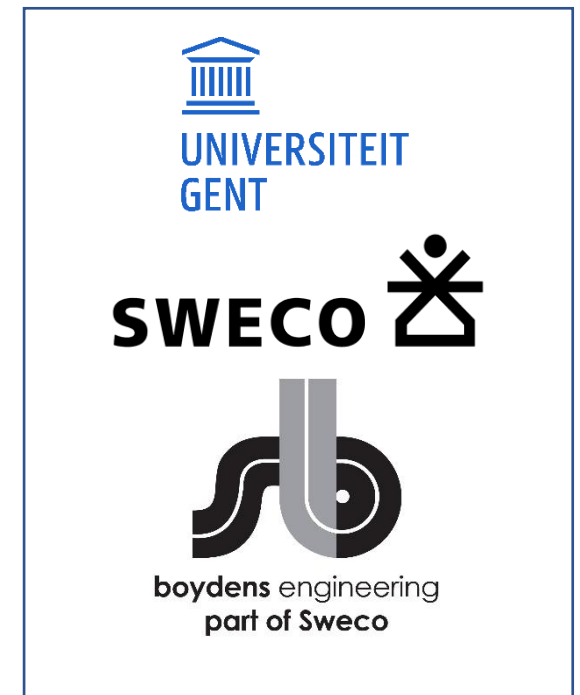

DE SCHIPJES 1.0

IWT Proeftuin (2014-2021):

Samengaan van gebouwsorg en energieoptimalisatie in historische woonerven



- Historisch erfgoed, monumentenzorg
- Energetisch & ecologisch
- Sociale economie
- Renovatie gebouwschil, ventilatie en verwarming
- Maximaal behoud gebruiksoppervlakte
- Collectief opwekkingsstelsel
- Scenario-analyse via dynamische simulaties

DE SCHIPJES 1.0

Scenarios

Scenario 1: hoge temperatuur

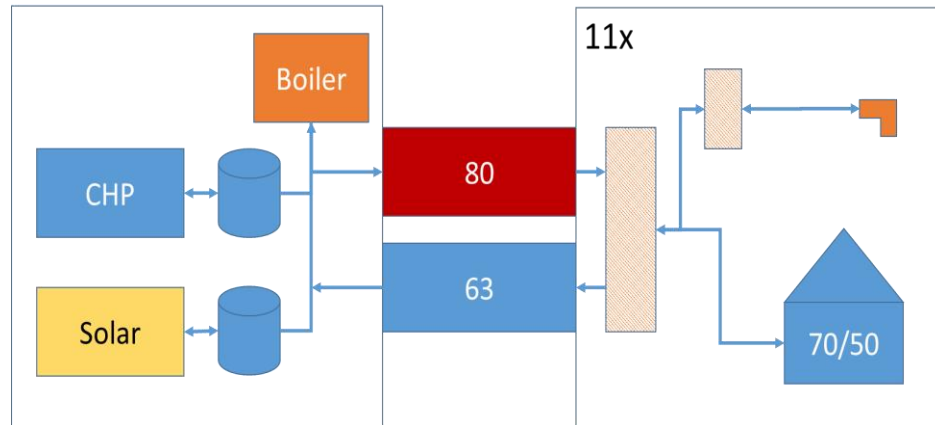

Scenario 2: intermitterende temperatuur

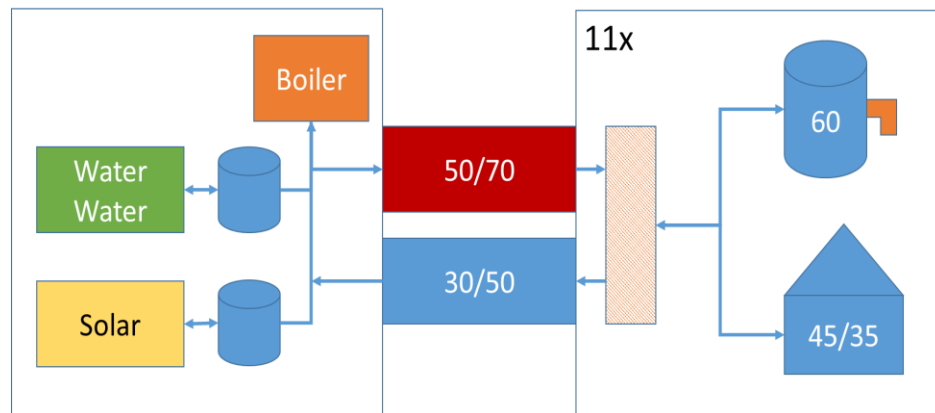
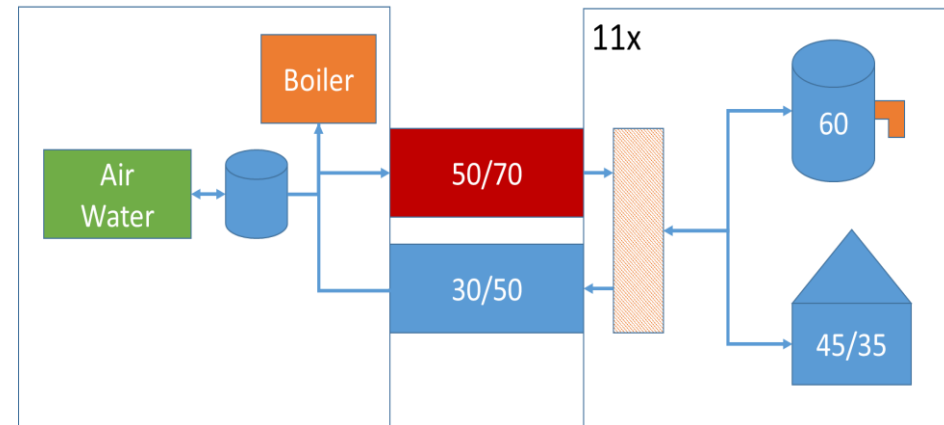

Scenario 3: intermitterende temperatuur

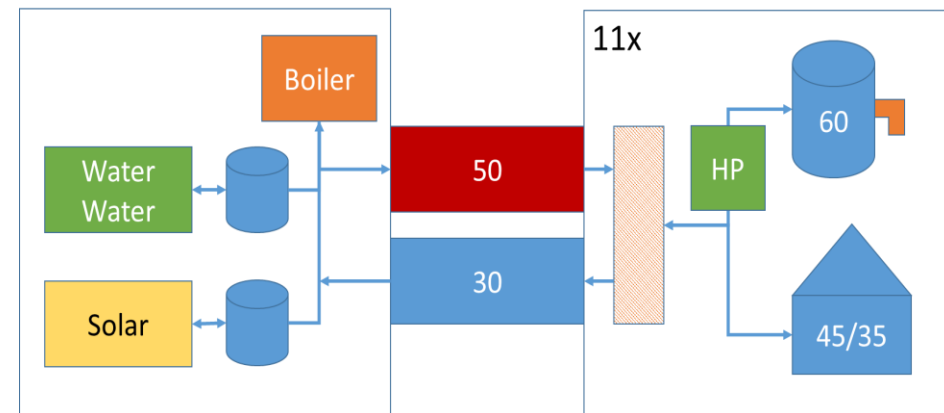

Scenario 4: lage temperatuur

DE SCHIPJES 1.0

Volledig hernieuwbaar, dus zonder gasketel

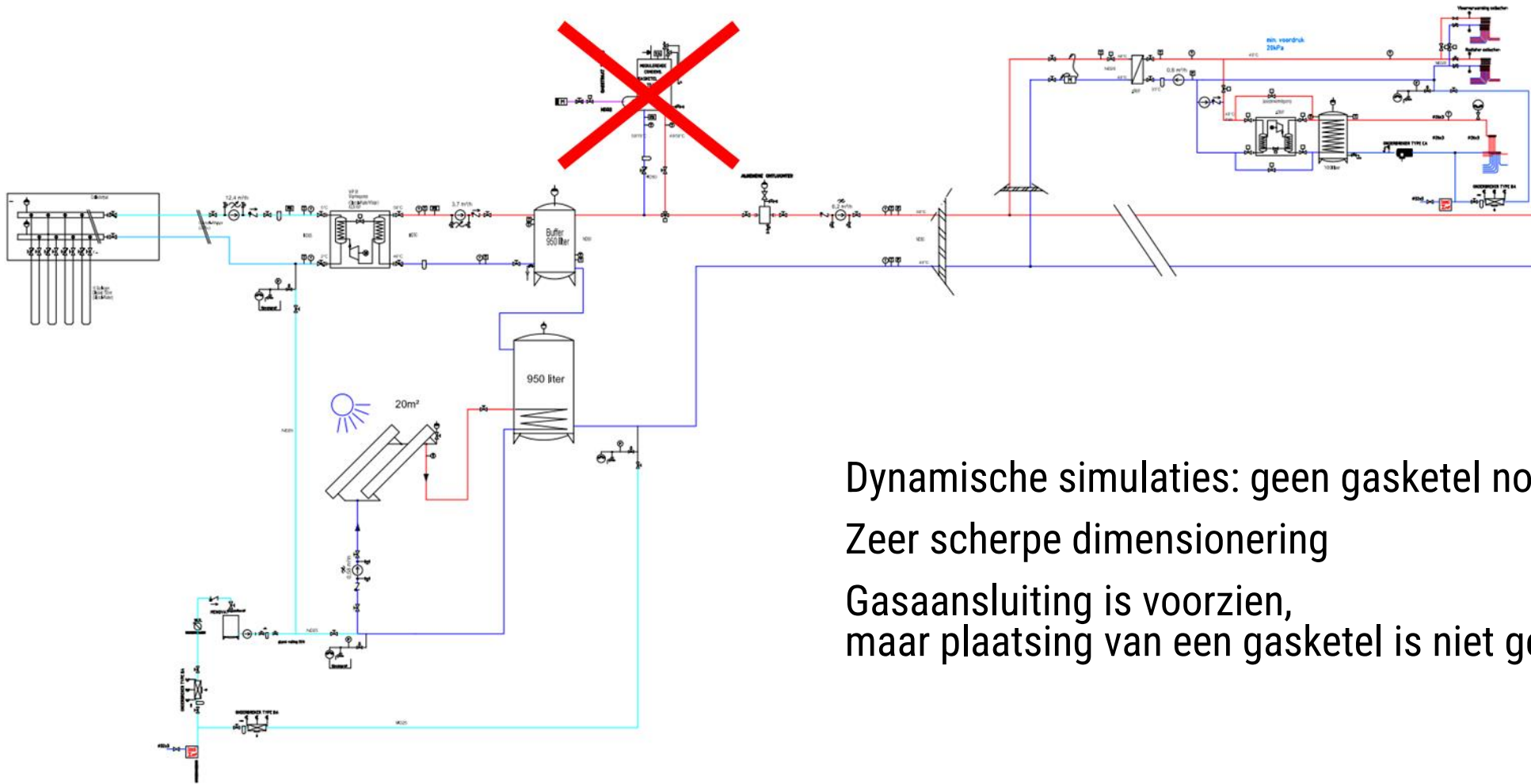

Dynamische simulaties: geen gasketel nodig
Zeer scherpe dimensionering
Gasaansluiting is voorzien,
maar plaatsing van een gasketel is niet gewenst

INNOVATIEVE AANSTURING

Model Predictive Control (MPC)

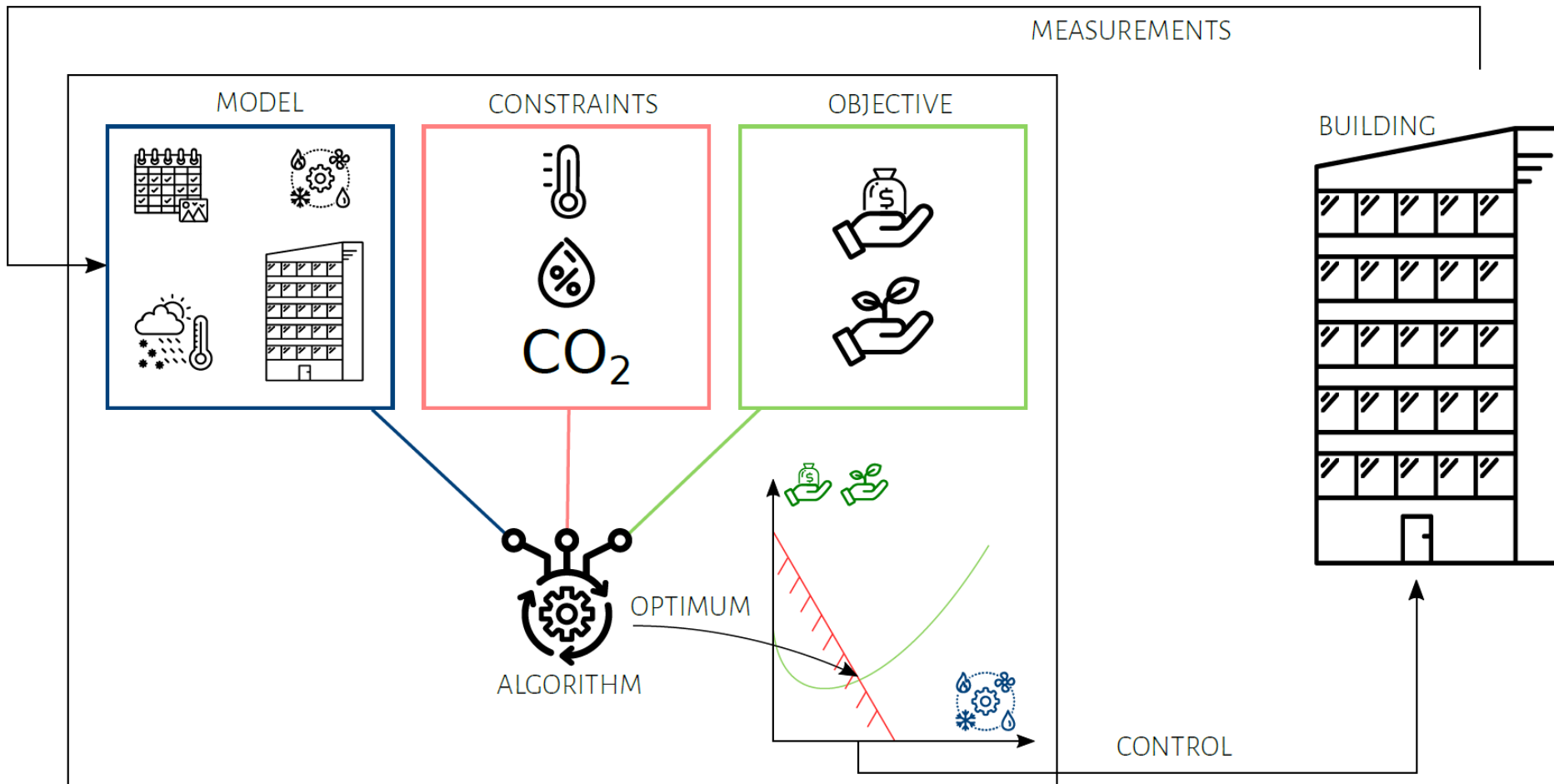

DE SCHIPJES 1.0

Nieuwe inzichten dankzij simulaties
conventionele aansturing (RBC) – innovatieve aansturing (MPC)

Winter 28-31 Januari	Thermisch discomfort per gebouw [Kh]	E_{el} [kWh]
RBC	6.7	578
MPC	0.6	505
Δ	Beter	-13%

Lente 27-30 april	Thermisch discomfort per gebouw [Kh]	E_{el} [kWh]
RBC	0.1	164
MPC	0.4	107
Δ	Equivalent	-35%

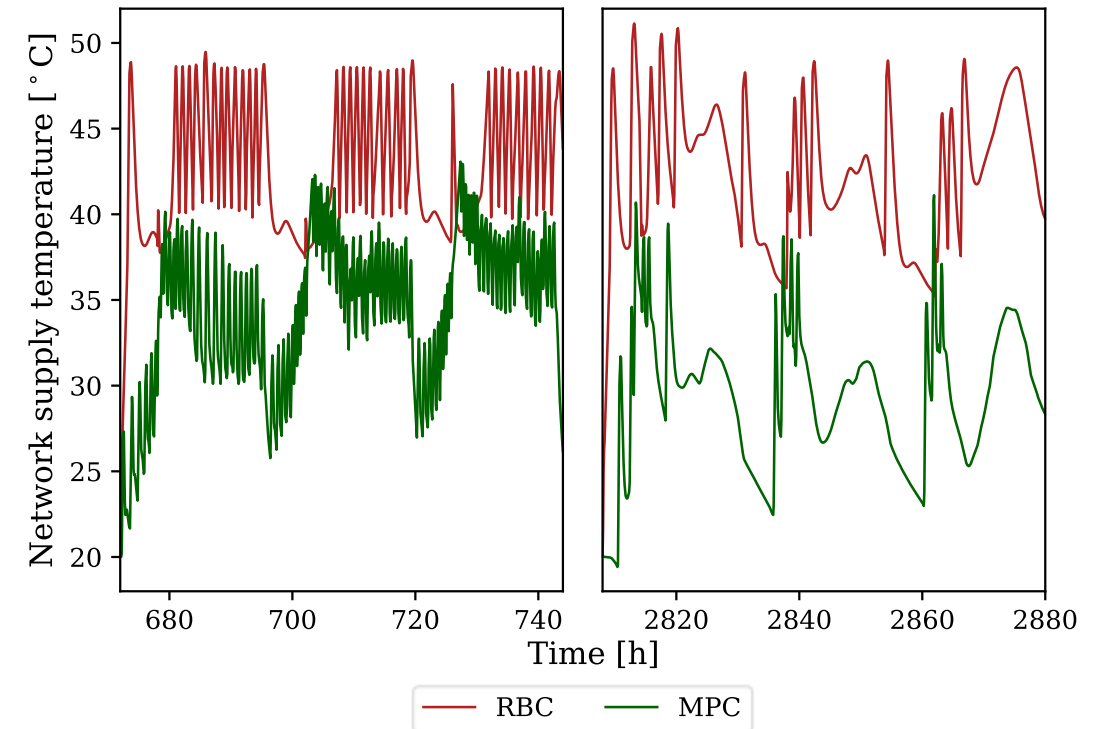

NAAR DE SCHIPJES 2.0



Hybride* collectieve systemen maken decarbonisatie haalbaar en betaalbaar

HYBRIDE WARMTEPOMPSYSTEEM (GEO-WP + LUCHT-WP)

voor maximale systeemefficiëntie en kosteneffectiviteit (CAPEX versus OPEX)

- GEO-WP
 - Verwarmingsgedomineerd → dalende bodemtemperatuur → lagere COP → gevaar voor thermische uitputting
 - Om de systeemefficiëntie hoog te houden meer boorputten nodig → duur en ruimte nodig
 - Dimensioneren op de piek is heel dure oplossing, en deze 100% capaciteit slechts voor een paar dagen per jaar
 - Merendeel van de warmtevraag is op veel minder dan 50% van de ontwerpcapaciteit
- Voeg een lucht-WP toe ... wat een kleiner boorveld toelaat!
 - Warmtevraag is er voor het merendeel van de tijd bij buitenluchtemperaturen die interessant zijn voor lucht-WP'en
 - **Optimale seizoensrendementen** in plaats van ogenblikkelijke rendementen → spaar de capaciteit van de GEO-WP voor momenten met lage buitenluchtemperaturen (terwijl de grondtemperatuur nog steeds hoog is omdat de lucht-WP werd ingezet voor gemiddelde buitenluchtemperaturen)
 - **Systeemregeling is dan cruciaal!**

* hybride = combinatie van meerdere hernieuwbare technologieën

Hybrid Model vs. Alternatives

ASHP + GSHP > 100% ASHP or 100% GSHP
(or any HP + Supplemental Fossil Fuel)

Doel WP7

WP7: Decision making support framework for replication of thermal demand electrification and improved energy efficiency

'External replication framework'

SEEDS innovaties:

- Hybrid Heat Pump systems
- Building envelope energy efficiency
- Integrated R²ES/storage systems
- Smart controls
- Energy flexibility and grid stability
- Interoperable platforms
- Automated demand response
- ...

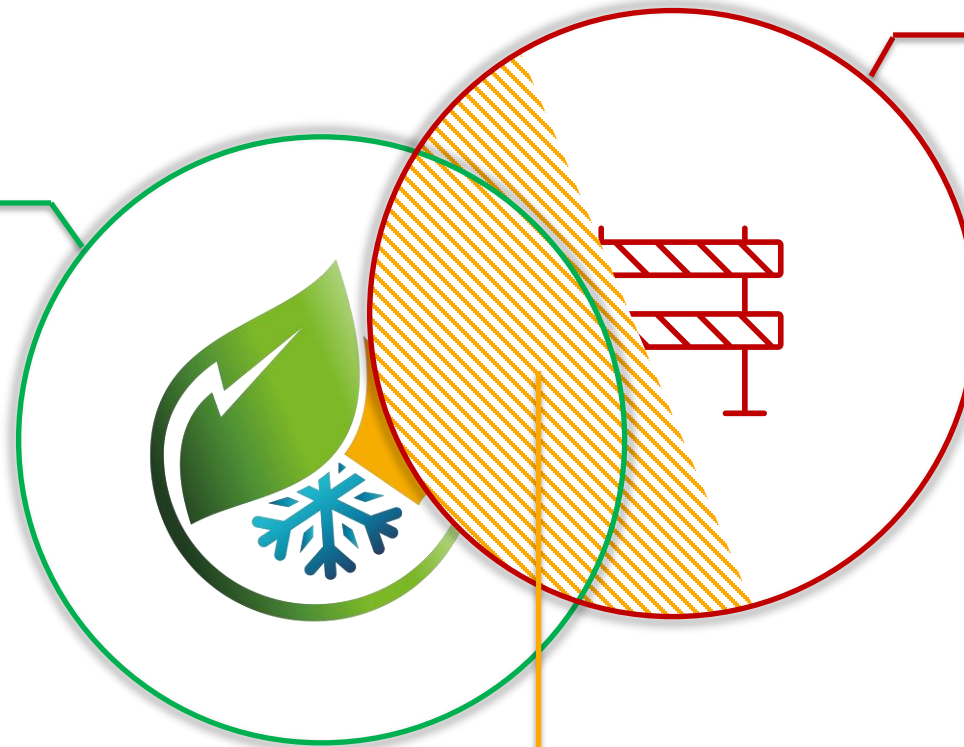

Barrières voor implementatie:

- Financieel:
 - Financieringsmechanismen
 - TCO
- Juridisch:
 - Spanningsveld privaat/publiek domein
 - Energiemarkt
- Organisatie:
 - Rollen & verantwoordelijkheden
- Initiatief:
 - Geschikte clusters
 - Waar te beginnen?
- Design:
 - Hoe robuust ontwerpen?
- ...

Hoofddoel van WP7

Wat zijn de barrières voor implementatie, en hoe kunnen we die verhelpen om replicatie te versnellen (via inzichten SEEDS)?

Blijf op de hoogte



HeriTACE

Future-proofing **Heritage** Buildings by
Optimising Comfort and Energy in **Time**
and **Space**



www.heritace.eu



SEEDS

ABOUT ▾ NEWS & EVENTS RESOURCES ▾ CONTACT US NEWSLETTER ✉ in



SEEDS

SEEDS project

SEEDS project: Cost-effective and replicable Renewable Energy Sources integrated electrified heating and cooling systems for improved energy efficiency and demand response.

The SEEDS project is co-funded by the European Commission and aims to boost the electrification of thermal systems in buildings through an integrated approach leveraging energy efficient renovation and smartification of HVAC systems.

LEARN MORE



- THE PROJECT
- THE CONSORTIUM
- THE DEMO SITES
- HORIZON EUROPE

www.project-seeds.eu

of mail: glenn.reynders@kuleuven.be ;-)